

Application

The PRAD (Positive) and the VRAD (Negative) pressure relief doors are designed to open automatically at 2 in. wg (0.50 kPa) above normal operating system pressure. The function of these doors is to prevent ductwork from imploding or exploding in the event the dampers close while the fan is still operating.

By opening outward or inward at a specified pressure setting, the doors permit rapid neutralization of the pressure differential between the inside and outside of the HVAC system. The pressure relief setting is factory set and tested prior to shipment.

Construction

| | Standard |
|-----------------------------------|--|
| Frame | .062 in. (1.6mm) thick aluminum extrusion, Z & T-shape |
| Door | .050 in. (1.3mm) thick aluminum extruded perimeter with 24 to 16 ga. (.7mm to 1.5mm) skin and polyurethane filled seal core (NFPA 90A compliant) |
| Insulation Rating | Up to R 6.5 |
| Trim Flange | 1 in. (25mm) around perimeter |
| Seal | Co-extruded PVC leaf gasket |
| Range of Settings | Factory adjusted pressure settings range from 2 in. to 12 in. wg (0.50 kPa to 3 kPa). Door is specifically set 1 in. (0.25 kPa) above normal operating system pressure, unless otherwise specified |
| Cable Assembly With Spring | Cable assembly limits door opening to 80°, preventing door and duct damage |
| Latch | Adjustable magnet assembly is factory set at desired relief pressure. Pressure must be given at time of order to properly place latch. Latch is field adjustable. |
| Service Temperature | -40°F to 120°F (-40° C to 49° C) |

Door Sizes and Pressure Ranges

| Size (W x H) | Pressure Setting Range |
|---------------------------------|-------------------------------|
| 10 in x 10 in (254 mm x 254 mm) | 2 - 12 in. wg (0.5 - 3 kPa) |
| 12 in x 12 in (305 mm x 305 mm) | 2 - 12 in. wg (0.5 - 4 kPa) |
| 18 in x 18 in (457 mm x 457 mm) | 2 - 10 in. wg (0.5 - 2.5 kPa) |
| 24 in x 24 in (610 mm x 610 mm) | 2 - 10 in. wg (0.5 - 2.5 kPa) |

Width and height dimensions are undersize $\frac{3}{16}$ in. (4.7 mm).



PRAD
(Positive)



VRAD
(Negative)

Dimensions

PRAD

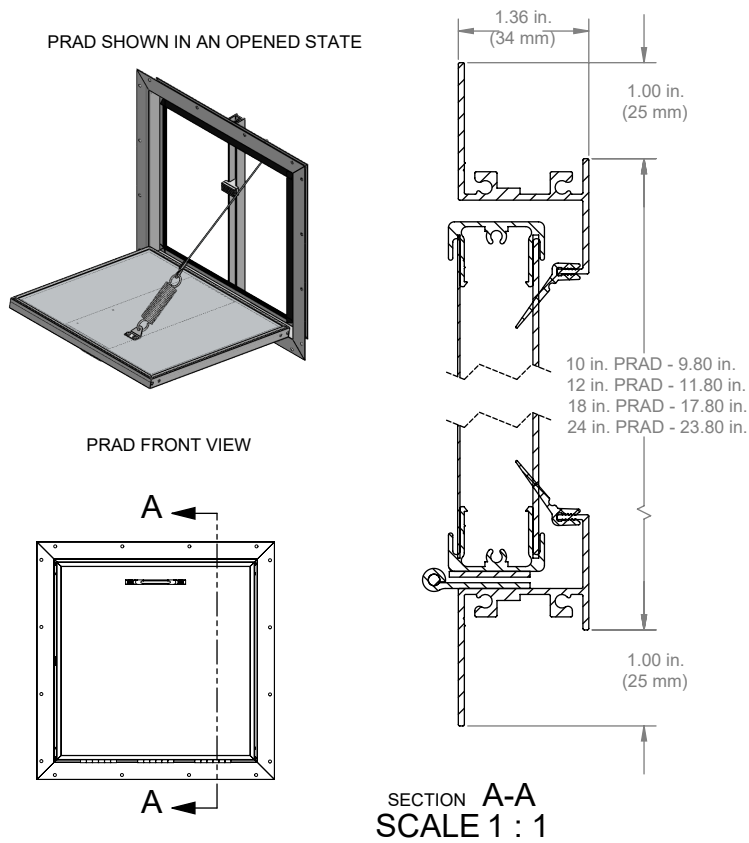

VRAD

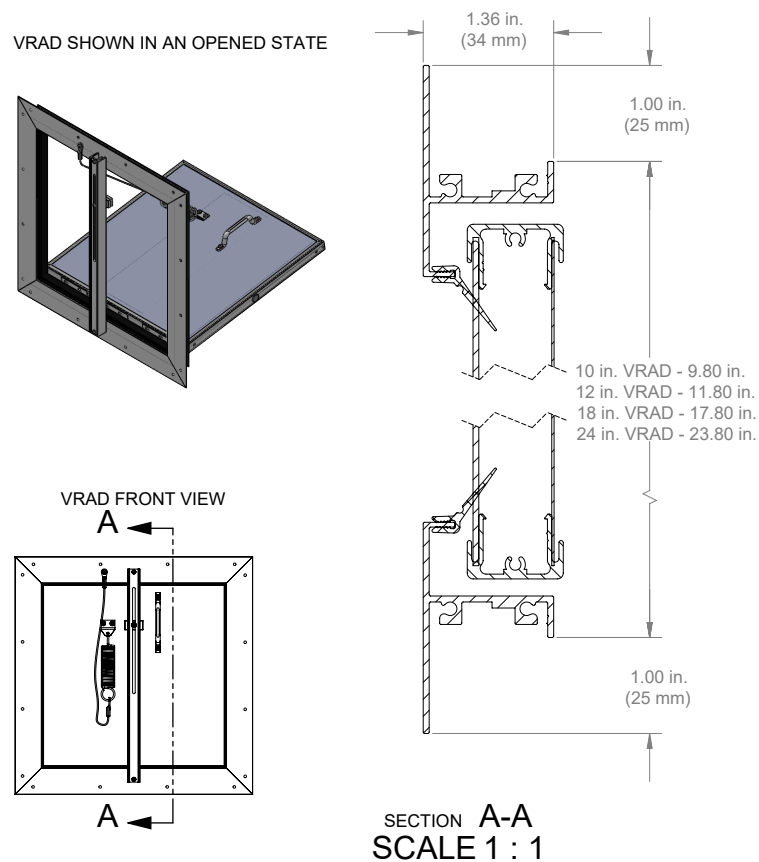

Selection & Performance Data

1. Locate the fan curve for the system (see figure A).
2. Determine the maximum pressure the ductwork is designed to handle. Locate where the maximum pressure of the ductwork intersects the fan curve (see Figure A).
3. The figure from step 2 gives the volume of air that should be relieved.
4. Refer to the Relief Airflow vs. Static Pressure chart (see Figure B).
5. Select an appropriate door size (standard 18 in. x 18 in. [457mm x 457mm]). Determine the volume of air the door will relieve at the maximum design pressure.
6. Divide step 2 by step 5 to determine the number of doors required.
7. Select the set point ranging from 2 in. wg to 12 in. wg (.5 kPa to 3 kPa). The set point is usually 1 in. (25mm) above normal operating pressure.

Figure A Fan Curve

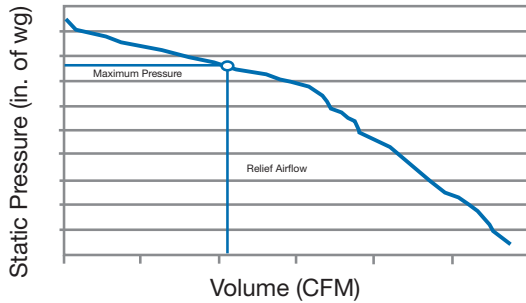

** Note: Fan curve should be supplied with Manufacturer's documentation.

Figure B

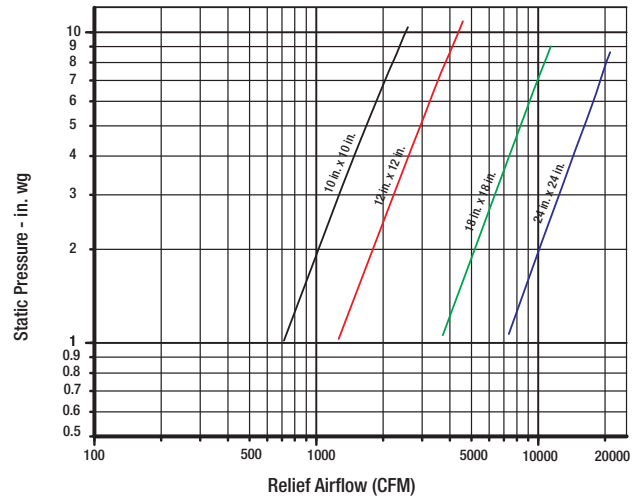

This table shows the amount of door leakage versus duct static pressure.

LEAKAGE

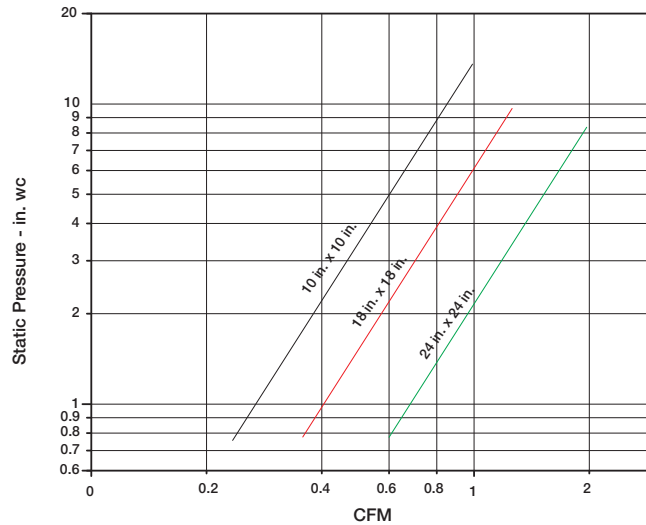

Note

- 1) Door must be installed vertically and level, with hinges down, for proper operation.
- 2) Desired static pressure settings should be given at time of order.
- 3) The pressure relief doors must be manually closed after opening due to excess pressure or vacuum.

Cut door opening to size of door selected. Doors are $\frac{3}{16}$ in. (4.7mm) undersize. Attach door using #10 self drilling screws.

Document Links



[INSTALLATION](#)



[SELECTION GUIDE](#)



[WARRANTY](#)



[SPECIFICATIONS](#)